

# CORBEILLE À PAPIER

## FICHE DE FABRICATION

temps estimé : 3h

### MATÉRIEL

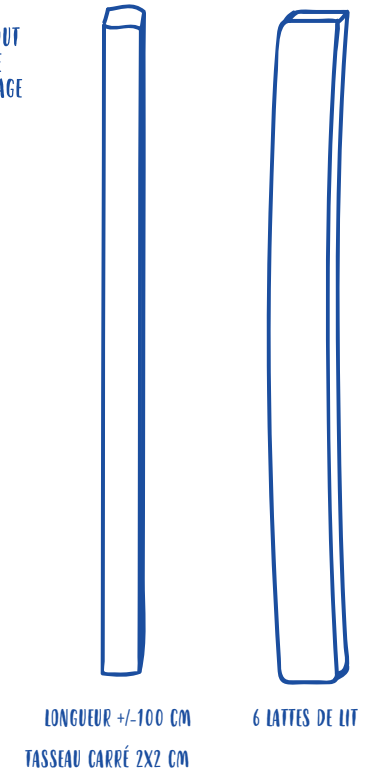
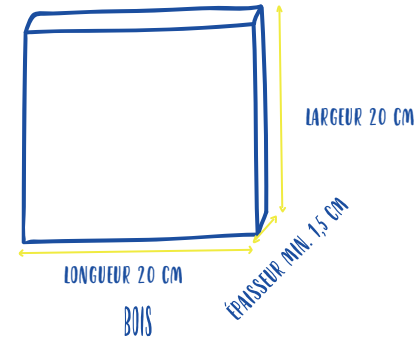
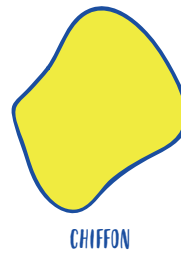
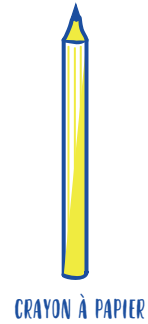
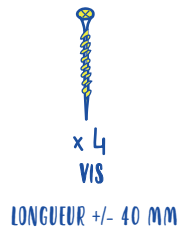
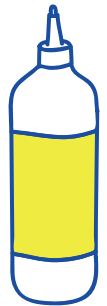
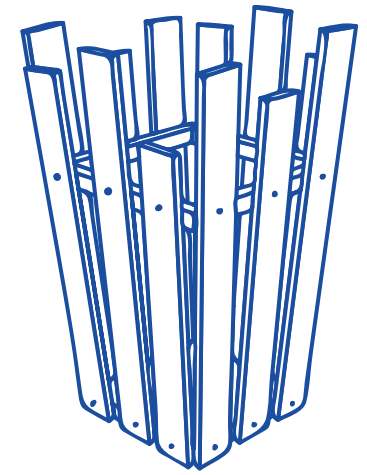
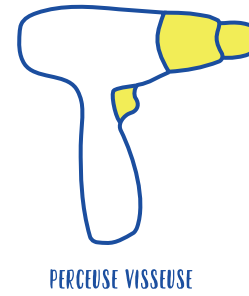
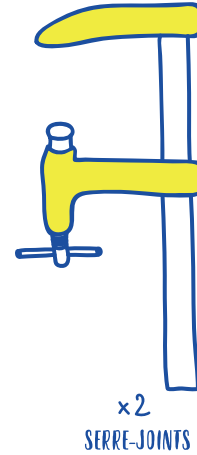
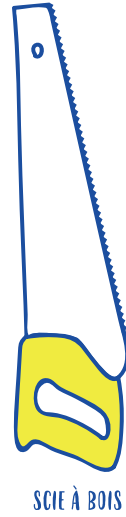
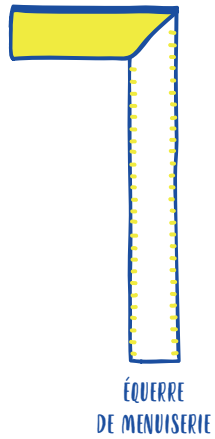

## ÉTAPES DE FABRICATION

- 1** Scier 4 sections de 23 cm dans le tasseau.  
Tracer un trait, scier, puis tracer le trait suivant, scier, etc.

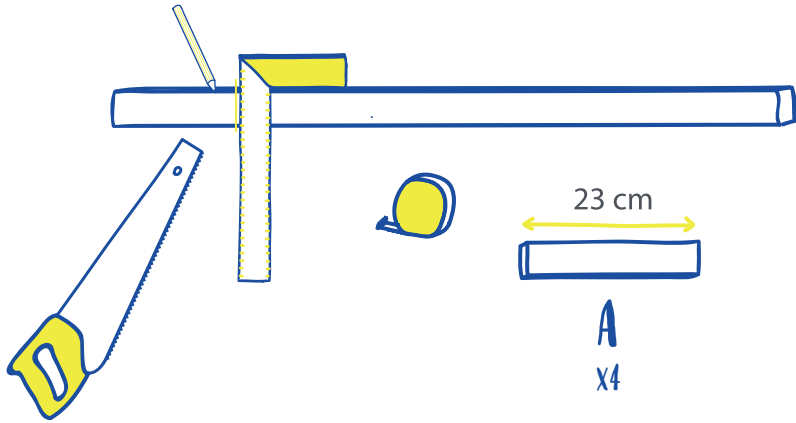

- 2** Scier les lattes pour obtenir 12 sections de tailles différentes, entre 30 et 40 cm.

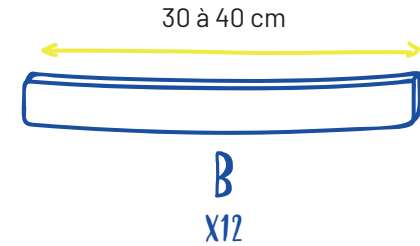

- 3** Assemblez les 4 sections «A» afin d'obtenir un cadre carré.  
Pré-percez à l'aide d'un foret à bois de diamètre inférieur à la vis. Mettez un point de colle à bois sur les parties en contact puis vissez.

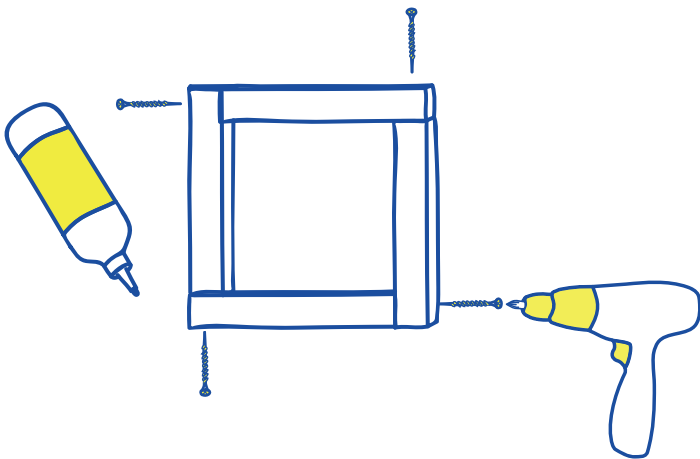

- 4** Vissez les lattes «B» à la planche carrée.

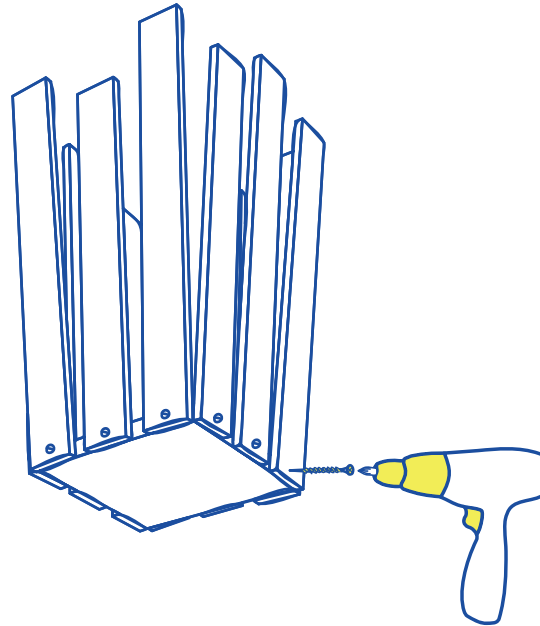

- 5** Glissez le cadre par le haut. Les lattes sont souples et vont s'écarter pour donner sa forme évasée à la corbeille. Vissez les lattes au cadre.

